



THE WORLD LEADER IN
FUME EXTRACTION TECHNOLOGY



Volume

1000

BOFA's high end fume extraction system combines extremely large filter capacity with high airflows and pressure. The V1000 features automatic flow control as standard giving consistent airflow throughout the life of the filters. 3 stage filtration, filter condition display, built in silencing and BOFA's 'Easi-Glide' filter location mechanism for easy, quick and safe filter change come as standard. This unit can cater for up to 15 operators as a centralised system or can be used to extract fumes from automated soldering machines.

STANDARD FEATURES:

- Turbines with high airflow and pressure
- Long life filters with low replacement cost
- 'Easi-Glide' filter location mechanism
- Automatic flow control system
- 3 stage filtration
- Filter condition display
- Built in silencing

OPTIONAL FEATURES:

- VOC gas sensor (Volatile Organic Compound)
- Remote stop / start interface
- Filter change / System fail signal
-  DeepPleat pre filter

High volume extraction
for hand and machine
soldering applications.



Featuring optional DeepPleat
filter technology

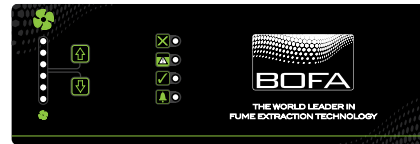

Automatic Flow Control

TYPICAL APPLICATIONS:

- Hand Soldering
- Arm Extraction
- Gluing
- Potting
- Conformed Coating
- Reflow Ovens
- Wave Soldering Machines



PART NUMBERS						
Model	Voltage	Part No.	Interface	24V Stop / Start	Filter change / System failure signal	VOC Monitoring
V 1000 Powder Coated	230V	E1242A	A3001	A2001	A2002	A2003
	115V	E1241A				

REPLACEMENT FILTERS						
Model	Pre Filter	Optional DeepPleat	HEPA Filter	Disposable Gas Filter 25kg	Refillable Gas Filter Tray	25Kg Refill Bag of Carbon
V 1000	A1030058	A1030222	A1030059	A1030061	A1030063	A1030064

TECHNICAL DATA		
	230V	115V
Dimensions (HxWxD)	1220 x 600 x 770mm	48 x 23.6 x 30.3"
Cabinet Construction	Brushed stainless steel / Powder coated mild steel	Brushed stainless steel / Powder coated mild steel
Airflow / Pressure	950m ³ /hr / 100mbar	559cfm / 100mbar
Electrical Data	230v 1ph 50/60Hz Full load current: 12.8 amps / 2.2kw	115v 60/50Hz Full load current: 25 amps / 2.2kw
Noise Level	< 63dBA*	< 63dBA*
Weight	155kgs	342lbs
Duct Size	125mm	5"
Duct Run	40mtrs	131ft

* At typical operating speed.

PRE FILTER SPECIFICATIONS	
Surface Media Area	2.5m ² approx
Filter Media	Glass Fibre
Filter Media Construction	8 Pocket Bag Filter
Filter Efficiency	F8 (95% @ 0.9 microns)

GAS/HEPA FILTER SPECIFICATIONS	
Surface Media Area	7.5m ² approx
HEPA Filter Media	Polyester
HEPA Media Construction	Maxi Pleat Construction with Webbing Spacers
Filter Efficiency	H13 (99.997% @ 0.3 microns)
Gas Filter	Treated Activated Carbon
Filter Housing	Zintec Mild Steel

HIGH VOLUME EXTRACTION UNIT ARM SPECIFICATIONS	
Maximum number of 32mm Arms	15
Maximum number of 50mm Arms, Cowls or Down Draft Trays	10
Maximum number of 75mm Arms, Cowls or Down Draft Trays	6

FILTER OPTION:

OPTIONAL DEEPPLEAT PRE FILTER SPECIFICATIONS	
Surface Media Area	30m ² approx
Filter Media	Glass Fibre
Filter Media Construction	Maxi Pleat Construction with Webbing Spacers
Filter Housing	Zintec mild steel
Filter Efficiency	F8 (95% @ 0.9 microns)

AIRFLOW THROUGH FILTERS

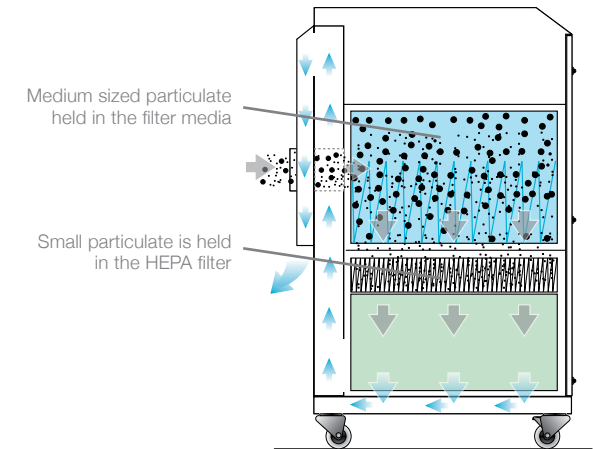
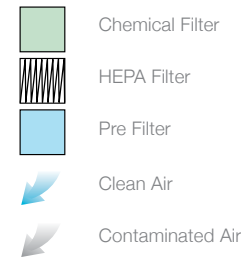

TECHNICAL SPECIFICATION

- | | |
|--|---------------------------------|
| 1 Unit / Filter Condition Display - Automatic Flow Control | 6 Door Hinge |
| 2 On / Off Switch | 7 Hose Inlet Connection - 125mm |
| 3 Signal / Interface Cable | 8 Exhaust Outlet |
| 4 Power Cable | 9 Motor Cooling Inlet |
| 5 Castors | 10 Door Latch |

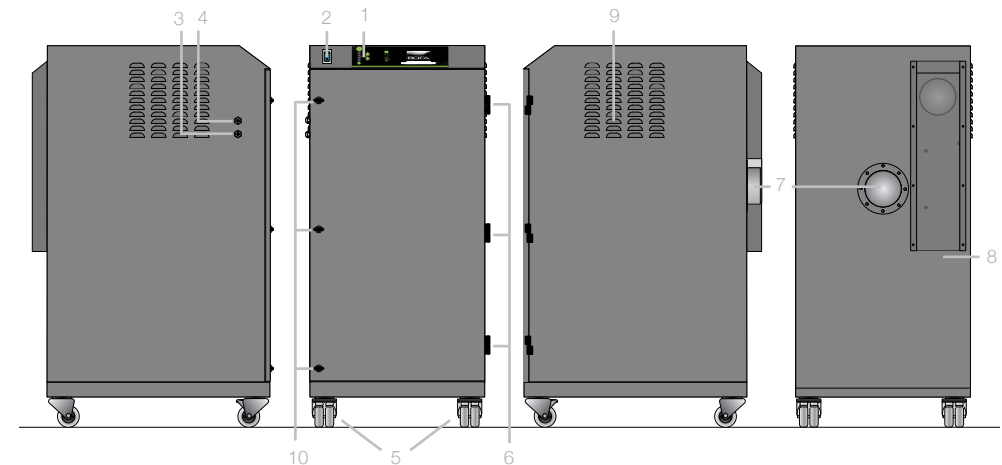

Other hose kits and filters are available. All of the above units are fitted with our standard filter combinations. For specific applications please call us for details. Replacement filters should always be ordered using the part number on the filters inside your extractor to ensure the correct filter is ordered. Datasheet correct at time of print.

Date: 14/2/12 V:1.2



BOFA INTERNATIONAL LTD

Tel: +44 (0) 1202 699 444 Fax: +44 (0) 1202 699 446 Email: sales@bofa.co.uk Web: www.bofa.co.uk

BOFA AMERICAS, INC

Tel: (618) 635 4465 Fax: (866) 707 2632 Email: sales@bofaamericas.com Web: www.bofaamericas.com

